



Single Section Softback

page 1

This is a useful bind to master since it can be adapted many ways by adding sections or a hard cover, this is the most basic form.



1. cut out a stack of pages for the book, For this example cut 8 pages: 240mm x 140mm

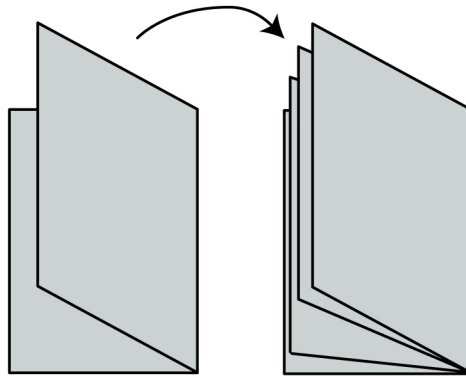

Fold the pages in half and sit them, one in another

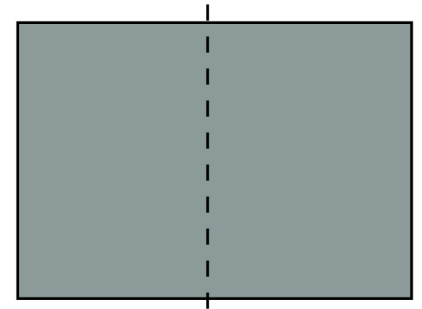

2. Cut a cover on heavier weight paper or card. The cover is slightly larger: 245mm x 145 mm

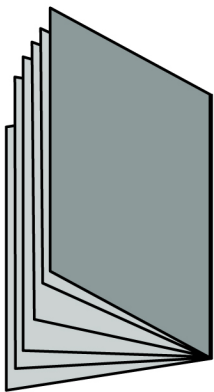

3. Holding all the pages and cover tightly together, rest them on some old card and using a bookbinder's awl punch 3 holes evenly down the spine - one centrally, one at the top and one at the bottom.

If you haven't got an awl, try a thick-needle, tapped with a small hammer - warning needles break rather easily

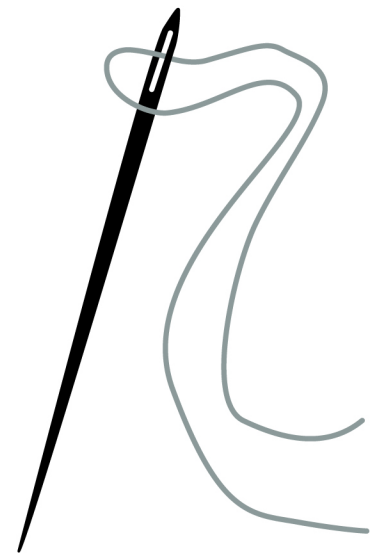
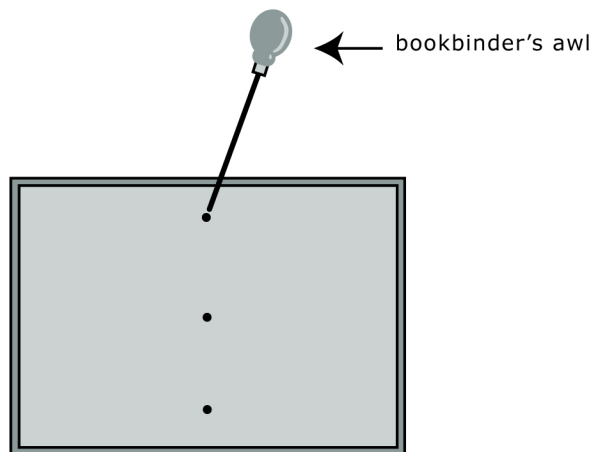

4. Thread a needle with bookbinding thread, pull so both ends are level - **but don't knot.**

You need more than you think, for this example try 80cm of thread, once doubled it will be 40cm long

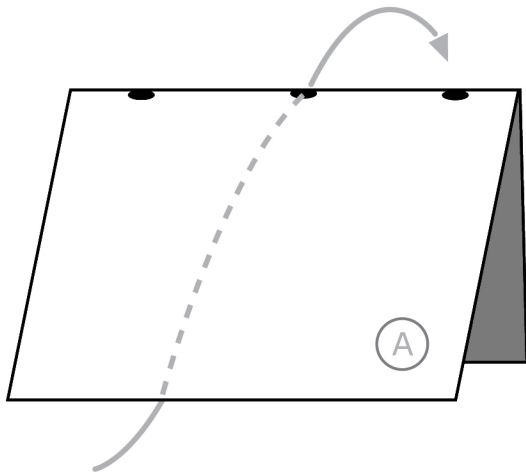

5. Sew the book together, following these diagrams.

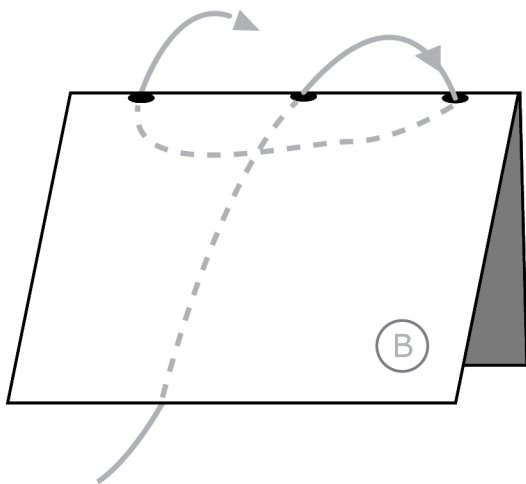

6. Reef-Knot

Tie the knot across the central thread to lock in place then trim - not too close to the knot

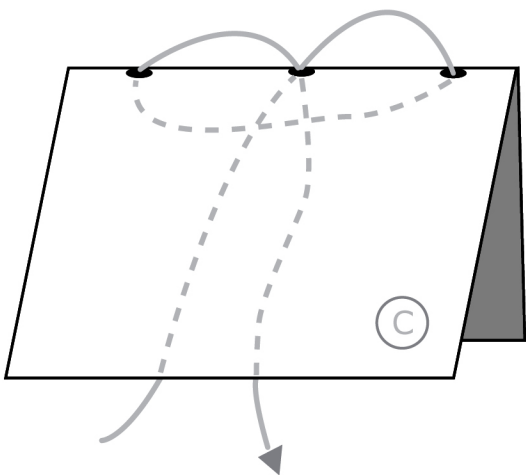
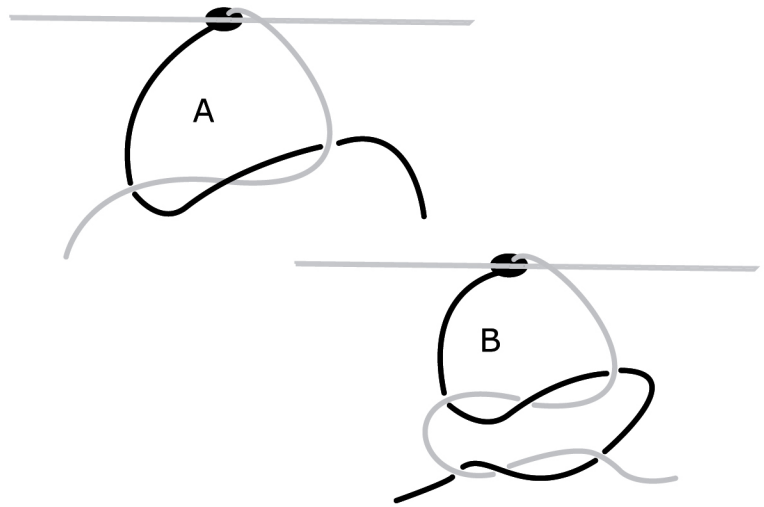

Close the book and press the folds again to finish the book. If you have lots of pages inside the book, they may need cutting square with a guillotine or a sharp knife & metal ruler. It is easier to do this when they've all been sewn together rather than when they're all loose

Once sewn, open the book flat with the inside facing you and tie a reef-knot to finish.

